

ESCO
SCIENTIFIC



Airstream® G4

Class II Type A2 Biological Safety Cabinets

*The Leading Energy-efficient, Quiet,
and Ergonomic Biosafety Cabinet in the World*

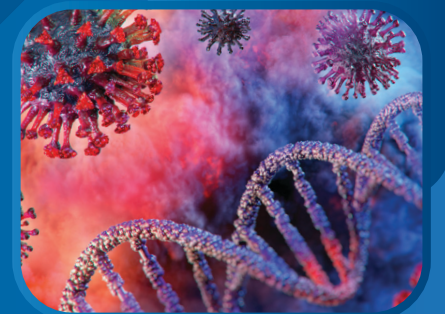



USB Port and Zero Volt Relay Contact

- USB Port to send operational information to Building Management System (BMS)
- Zero Volt Relay Contact to turn ON/OFF exhaust blower and signal the building alarm

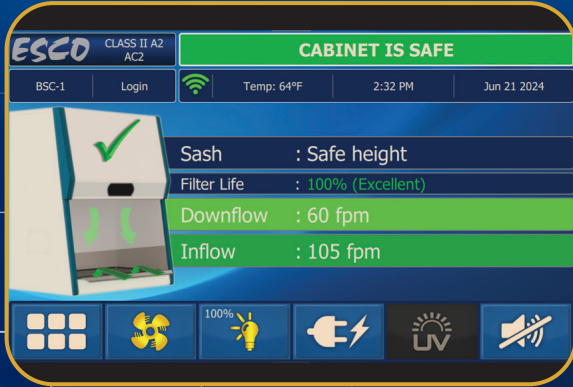

Centurion Touchscreen Controller

- 7" Capacitive Touch Screen, intuitive to use like phones
- Displays key safety information graphically on one screen
- Built-in guide to use the cabinet and respond to situations
- Centered and angled down for easy reach & viewing
- Datalogger to assist diagnostics and send info to BMS
- Optional: 21 CFR Part 11 Compliance



One-Piece Interior Wall

- Double layer side walls with negative pressure
- Easy to reach service fixture and outlets
- Large radius corner for easy cleaning



Unique Stainless Steel (S-Series) and Glass Hybrid (E-Series) Wall

- Large corner radius for easy cleaning
- Easy to reach service fixture and outlets



Removable Paper Catch

- Easy-to-clean
- Optional pre-filter can be fitted

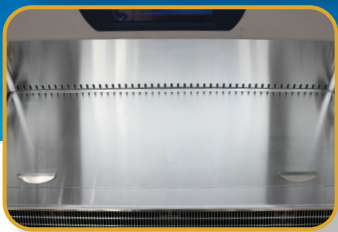

Raised Ergonomic Arm Rest

- Helps prevent grille blocking
- Comfortable working posture

Dished Work Tray

- Contains spillage
- Angled edge for easy cleaning
- V-shaped grille to prevent blocking
- Work tray holder for drain pan cleaning



Available in 0.9, 1.2, 1.5, and 1.8 meter width (3', 4', 5', and 6')





Airstream®
Class II Type A2 Biosafety Cabinet

Airflow Sensor

- Monitors real-time airflow for safety
- Alerts the user if airflow is insufficient



Energy-efficient DC ECM Blower

- The leading energy efficient Class II Type A2 Biosafety Cabinet in the world with 70% energy savings compared to AC motor
- Stable airflow despite building voltage fluctuations and filter loading
- Standby mode to further reduce power consumption by 60%

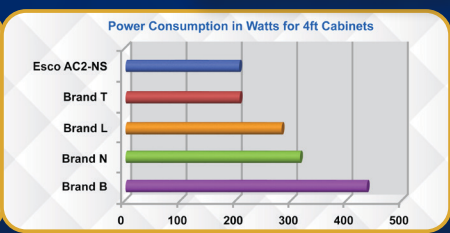
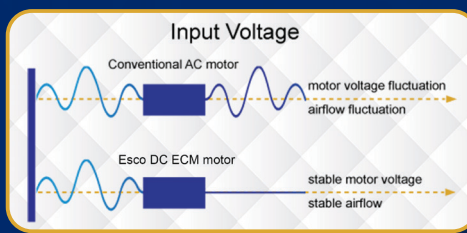

ULPA Filter

- 10x Filtration efficiency of HEPA filter
- Creates ISO Class 3 work zone instead of industry-standard ISO Class 5
- Same 10 years filter life and replacement cost as HEPA filters

Dynamic Chamber™

- Blower plenum and side walls are surrounded by negative pressure
- Prevents contaminants from escaping outside
- Steel plenum with Isocide™ coating, instead of flexible bag plenum, to prevent contamination leak

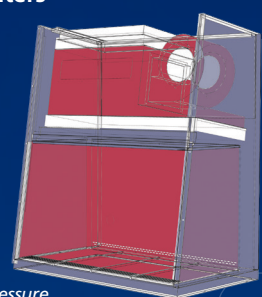

Positive pressure
Negative pressure

User Modified Pass-Through / Cable Port

- 3" Port with 1/4" hole on rubber membrane inside
- NSF-approved. Surrounded by negative pressure
- Allows cables and tubes to exit with fully closed sash



Angled Sash

- 10° angled front to optimize user comfort, reduce glare and maximize reach into the work area



ISOCIDE™ Powder Coat

- Silver-ion impregnated powder coat
- Inhibits microbial growth to improve safety
- Prevents the plenum from becoming biohazard landfill

Standards Compliance and Certifications				
Performance	Air Quality	Filtration	Electrical Safety	Electromagnetic Compatibility (EMC)
NSF / ANSI 49	ISO 14644.1, Class 3, Worldwide, US Fed Std 209E, Class 1 USA JIS B9920, Class 3, Japan	EN-1822 (H14), Europe IEST-RP-CC001, USA	UL 61010-1 3rd Ed, USA CSA22.2, No.1010-192, Canada IEC61010-1, Worldwide	EN IEC 61326-1 Group 1 / Class A

Cabinet Filtration System

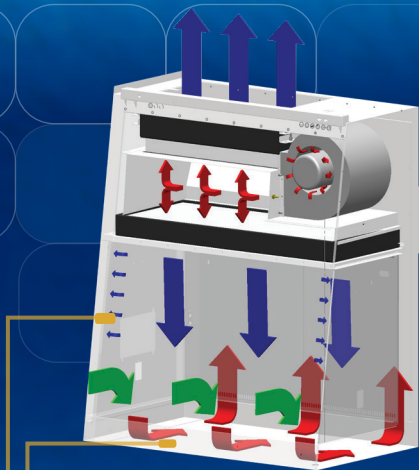

Dynamic air barrier, where inflow and downflow converge

Side capture zones

- ULPA-filtered air
- Unfiltered / potentially contaminated air
- Room air / Inflow air

- Ambient air is pulled through front grille to create inflow, without going into the work surface. Inflow is joined by half of the downflow, to create front air curtain that is fine-tuned to create large performance envelope. The combined air stream travels through the back air column towards the blower.
- Approximately 1/3 of the air in the common plenum is exhausted through the ULPA filter to the room. The remaining 2/3 of the air is passed through the downflow ULPA filter and into the work area as a vertical laminar flow air to create ISO Class 3 work surface and prevents cross contamination.
- Near the work surface, the downflow splits. About half goes to the front grille, and half goes to the rear grille. A small portion enters the side capture zones to prevent dead air corners (small blue arrows).
- The design was optimized to give large performance envelope, that provides operator and product protection from the Nominal point.

The Performance Envelope Concept

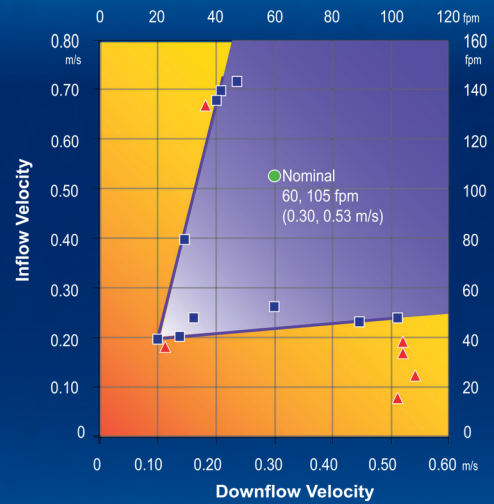

- Nominal Airflow
- Personnel / Product Protection
- Area of Personnel and Product Protection
- ▲ NO Personnel / Product Protection
- Area of NO Personnel and Product Protection

Engineering Drawing

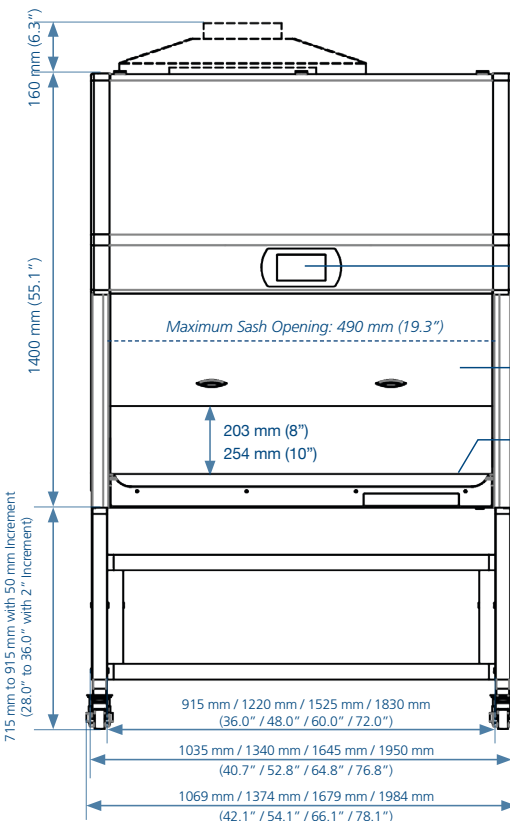
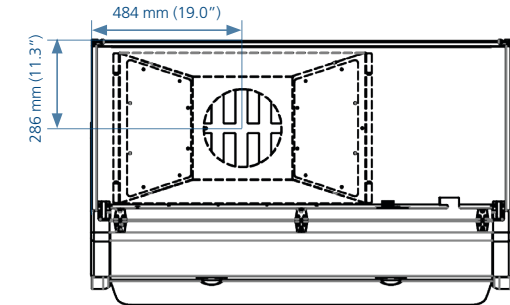

1. Centurion 7" Touchscreen Control System
2. Tempered Glass - Sliding Sash Window
3. Stainless Steel Dished Work Tray
4. Electrical/Electronic Panel
5. Dimmable LED lamp
6. Provision for IV Bar (Optional)
7. Service Fixture Retrofit Kit Provision
8. Electrical Outlet (Max. 5 Amp Total)
9. Stainless Steel Side Wall
10. Stainless Steel Curved Armrest
11. Exhaust Collar (Optional)
12. Exhaust ULPA (H14) Filter
13. ECM Blower
14. Downflow ULPA (H14) Filter
15. UV Lamp
16. Cable Port
17. Caster wheel - Leveling Feet Combo

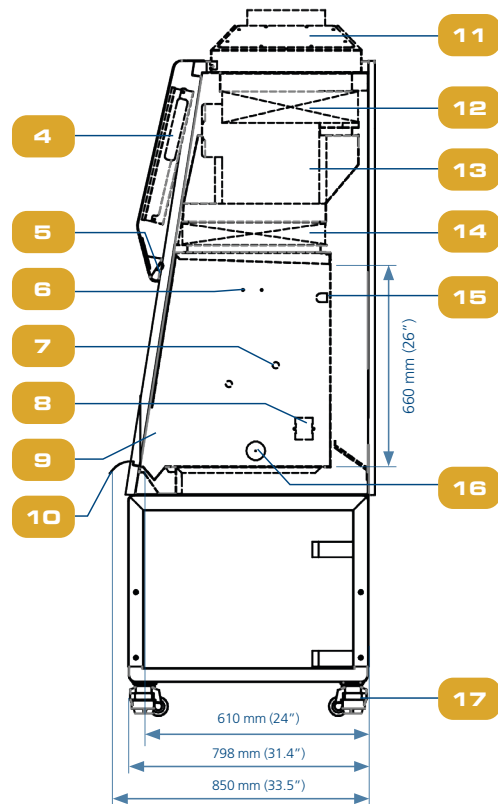

Airstream® NS G4

Class II Type A2 • Biological Safety Cabinets

TECHNICAL SPECIFICATIONS

Model	Stainless Steel Side Walls	8" Sash Opening	AC2-3S9-NS G4 8" 2011429	AC2-4S9-NS G4 8" 2011403	AC2-5S9-NS G4 8" 2011431	AC2-6S9-NS G4 8" 2011433
	Glass Hybrid Side Walls	10" Sash Opening	AC2-3S9-NS G4 10" 2011926	AC2-4S9-NS G4 10" 2011927	AC2-5S9-NS G4 10" 2011928	AC2-6S9-NS G4 10" 2011929
		8" Sash Opening	AC2-3E9-NS G4 8" 2011421	AC2-4E9-NS G4 8" 2011423	AC2-5E9-NS G4 8" 2011425	AC2-6E9-NS G4 8" 2011427
Nominal Size			0.9 meter (3')	1.2 meter (4')	1.5 meter (5')	1.8 meter (6')
External Dimensions (W x D x H)			1035 x 850 x 1400 mm (40.7" x 33.5" x 55.1")	1340 x 850 x 1400 mm (52.8" x 33.5" x 55.1")	1645 x 850 x 1400 mm (64.8" x 33.5" x 55.1")	1950 x 850 x 1400 mm (76.8" x 33.5" x 55.1")
Gross Internal Dimensions (W x D x H)			915 x 610 x 660 mm (36.0" x 24.0" x 26.0")	1220 x 610 x 660 mm (48.0" x 24.0" x 26.0")	1525 x 610 x 660 mm (60.0" x 24.0" x 26.0")	1830 x 610 x 660 mm (72.0" x 24.0" x 26.0")
Usable Work Area			0.45 m ² (4.9 ft ²)	0.6 m ² (6.5 ft ²)	0.75 m ² (8.2 ft ²)	0.9 m ² (9.8 ft ²)
Working Opening			203 mm (8") / 254 mm (10")			
Maximum Opening			490 mm (19.3")			
Average Inflow Velocity			105 fpm (0.53 m/s)			
Average Downflow Velocity			60 fpm (0.30 m/s)			
Airflow Volume	Inflow / Exhaust Without Ducting	8" Sash Opening	356 cmh (210 cfm)	473 cmh (280 cfm)	593 cmh (350 cfm)	709 cmh (417 cfm)
		10" Sash Opening	446 cmh (263 cfm)	594 cmh (350 cfm)	744 cmh (438 cfm)	891 cmh (525 cfm)
	Downflow	8" Sash Opening	566 cmh (333 cfm)	751 cmh (442 cfm)	942 cmh (554 cfm)	1127 cmh (663 cfm)
		10" Sash Opening	566 cmh (333 cfm)	751 cmh (442 cfm)	942 cmh (554 cfm)	1127 cmh (663 cfm)
	Required Exhaust with Optional Thimble Exhaust Collar	8" Sash Opening	390 cmh (230 cfm)	526 cmh (310 cfm)	627 cmh (369 cfm)	780 cmh (459 cfm)
		10" Sash Opening	614 cmh (362 cfm)	647 cmh (382 cfm)	786 cmh (463 cfm)	948 cmh (559 cfm)
	Static Pressure For Optional Thimble Exhaust Collar	8" Sash Opening	15-25 Pa (0.06-0.10 in H ₂ O)	25-35 Pa (0.10-0.14 in H ₂ O)	25-35 Pa (0.10-0.14 in H ₂ O)	45-55 Pa (0.18-0.22 in H ₂ O)
		10" Sash Opening	20-30Pa (0.08-0.12 in H ₂ O)	30-40Pa (0.12-0.16 in H ₂ O)	35-45Pa (0.14-0.18 in H ₂ O)	50-60Pa (0.20-0.24 in H ₂ O)
ULPA Filter Typical Efficiency			>99.999% at 0.1 to 0.3 micron, ULPA as per IEST-RP-CC001.3 USA >99.999% at MPPS, H14 as per EN 1822 EU			
Sound Emission per NSF / ANSI 49*			55.8 dBA	59.5 dBA	59.8 dBA	62.8 dBA
LED Lamp Light Intensity			117 foot candles (1260 lux)	122 foot candles (1313 lux)	113 foot candles (1216 lux)	114 foot candles (1227 lux)
Cabinet Construction	Main Body		1.2 mm (0.05") / 18 gauge EG Steel with Isocide™ Oven-Baked Epoxy-Polyester Anti-microbial Powder Coating			
	Work Zone		1.5 mm (0.06") / 16 gauge, Stainless Steel 304, 4B finish			
	Side Walls	Stainless Steel (S Series)	1.5 mm (0.06") / 16 gauge, Stainless Steel 304, 4B finish			
		Glass Hybrid (E Series)	6 mm thickness UV-absorbing Tempered Glass			
Sash Glass Material		6 mm thickness UV-absorbing Tempered Glass				
Electrical** 110-130 VAC, 50/60 Hz	Nominal Power Consumption (W)		132	184	242	333
			148	180	255	338
	Heat Load (BTU / Hr)		450	628	826	1136
			505	614	870	1153
	Cabinet Full Load Amps (FLA)		15	15	15	15
			15	15	15	15
Net Weight			203 Kg (448 lbs)	245 Kg (540 lbs)	303 Kg (668 lbs)	361 Kg (796 lbs)
Shipping Weight			231 Kg (509 lbs)	300 Kg (661 lbs)	369 Kg (814 lbs)	443 Kg (977 lbs)
Shipping Dimensions, Maximum (W x D x H)			1200 x 850 x 1950 mm (47.2" x 33.5" x 76.8")	1450 x 850 x 1950 mm (57.1" x 33.5" x 76.8")	1720 x 850 x 1950 mm (67.7" x 33.5" x 76.8")	2050 x 850 x 1950 mm (80.7" x 33.5" x 76.8")
Shipping Volume			2.0 m ³ (70.64 f ³)	2.5 m ³ (88.2 f ³)	3.0 m ³ (105.9 f ³)	3.6 m ³ (127.1 f ³)

Disclaimer: Technical Specifications may be subjected to further changes without prior notice.

*Noise reading in open field condition / anechoic chamber. Noise reading in normal room varies by room size, layout, and background noise, but may reach roughly 3-4 dBA above these values.

**Electrical power consumption is an measurement of new unit with clean filter operated within nominal setpoint. Result per unit may vary.

Options and Accessories

Exhaust Collar		ECO-F-LA2/AC2-3 G4 5171097	ECO-F-LA2/AC2-4 G4 5171098	ECO-F-LA2/AC2-5 G4 5171099	ECO-F-LA2/AC2-6 G4 5171100
Exhaust Damper		DAMPER-10 5170104			
UV Lamp		UV-15A-L 5170251	UV-30A-L 5170255		
IV Bar		IV-955 5170499	IV-1215 5170231	IV-1520 5170500	IV-1870 5170501
Electrical Outlet	GFCI	EO-GFCI 5170071			
Service Fixtures	US SF-Universal-20 mm	SF-2U22 5170504			
Support Stand	Telescoping Stand with Caster Wheels	STA-3A0 5131340	STA-4A0 5131341	STA-5A0 5131427	STA-6A0 5131389
	Motorized Stand Height with Levelling Feet	SPML-3A2 5131503	SPML-4A2 5131504	SPML-5A2 5131505	SPML-6A2 5131506
	Motorized Stand Height with Levelling Feet and Seismic Bracket		SPML-4A2-SB 5131403	SPML-5A2-SB 5131443	SPML-6A2-SB 5131404
	Motorized Stand Height with Caster Wheels	SPMC-3A2 5130093	SPMC-4A2 5130047	SPMC-5A2 5130100	SPMC-6A2 5131141
	Motorized Stand with Castors Cradle		SLC-4A2 G4 with 20" piston 5131441	SLC-5A2 G4 with 20" piston 5131447	SLC-6A2 G4 with 20" piston 5131440
Pipette Storage Shelf		5260327			
Arm Rest Padding		MEWREST 5170127			
Foot Rest		FT-REST 5170492			
Laboratory Chair		ME-LD-AR360 1150006			
IQOQ Protocol		9010179			

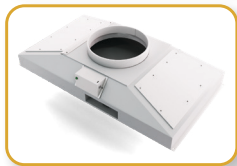

ECO-F-LA2-4 G4



UV-_A-L

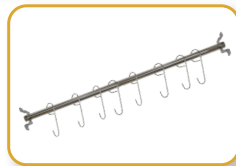

IV-_



EO-GFCI



SF-2U-22



STA-_A0



SPML-_A2



SPMC-_A2



SLC-_A2 G4 20"



Pipette Storage Shelf



MEWREST



FT-REST

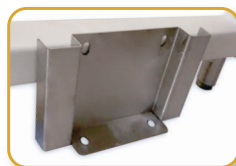

Seismic Bracket



ME-LD-AR360



IQOQ

Life Science Tools



Biological Safety Cabinets



Laminar Flow Cabinet



Animal Workstations



CO₂/O₂ Incubators

Chemical Research



Ducted Fume Hoods



Ductless Fume Hoods



USP 797 / 800
Compliant Isolators



Powder Containment
Workstations

Pharma Compounding

Medical (IVF)

PCR



Multi-room Incubators



Time-Lapse Incubators



IVF Workstations



PCR Workstations

Bioprocessing

Pharmaceutical



Bioreactors



cGMP and Filling Line Isolators



Air Showers and Pass Boxes



Downflow Booths

ESCO LIFESCIENCES GROUP

42 LOCATIONS IN 21 COUNTRIES ALL OVER THE WORLD



- 📍 Global Offices
- 📍 Licensee
- 📍 Distributors
- 📍 Factories
- 📍 R&D Centers
- 📍 Regional Distribution Centers

Follow us on social media, download our apps, and scan the QR code for more info.



@EscoLifesciences



@EscoLifesciences



@EscoLifesci



@Esco



@EscoLifesciences



@EscoLifesciences



Esco Lifesciences



Esco Lifesciences

ESCO

LIFESCIENCES GROUP

Esco Technologies, Inc. • 903 Sheehy Drive, Suite F, Horsham, PA 19044, USA
Tel: +1 215-441-9661 • eti.admin@escolifesciences.com

Esco Micro Pte. Ltd. • 19 Changi South Street 1 • Singapore 486 779
Tel +65 6542 0833 • mail@escolifesciences.com
www.escolifesciences.com

Esco Lifesciences Group Offices: Bangladesh | China | Denmark | Germany | Hong Kong | India | Indonesia | Italy | Japan | Lithuania | Malaysia | Myanmar | Philippines | Russia | Singapore | South Africa | South Korea | Taiwan | Thailand | UAE | UK | USA | Vietnam

9010510_AC2 Gen 4_US-LTR_vA_082224_HR
Esco can accept no responsibility for possible errors in catalogues, brochures and other printed materials. Esco reserves the right to alter its products and specifications without notice. All trademarks and logotypes in this material are the property of Esco and the respective companies.